

KEILHAUER

Hardware Included

1 1/4" Back +

Arm Screw (x6)



1" Out Arm

Screw (x4)



3/4" Mechanism

Screw (x4)



Tool Required

Hex Allen Key



6C Assembly Instructions

1 a)

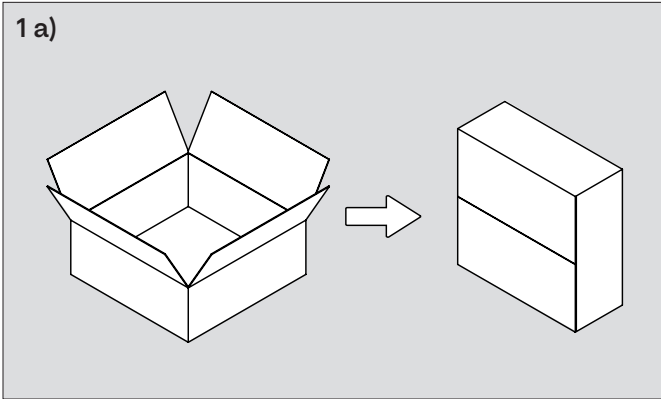

Carefully open the box as it aids in assembly. After removing the components, close the box, and turn it onto its side as shown.

1 b)

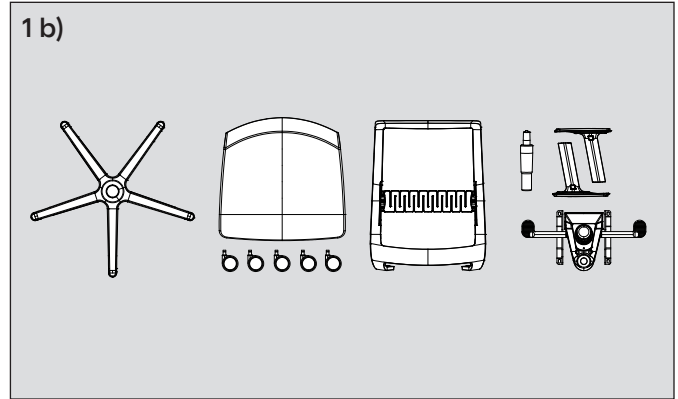

Included components (from left to right): Base, upholstered seat, casters (x5), back with adjustable lumbar, pneumatic height adjustment column, adjustable arms (x2), mechanism, and hardware (shown above).

2

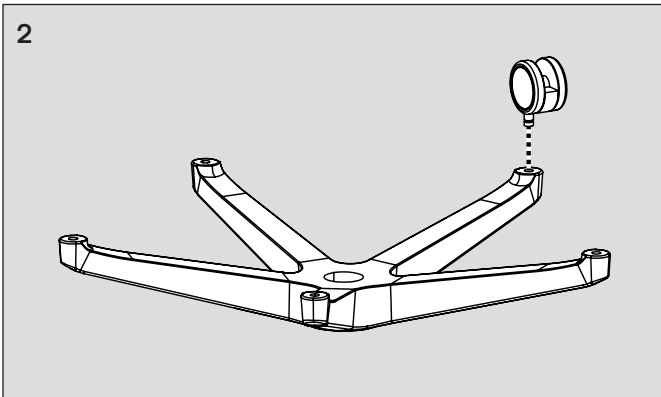

Press all five casters into the base. Some pressure may be required.

3

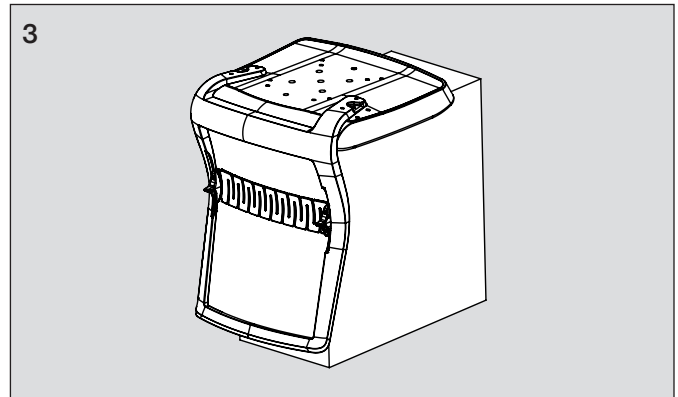

With the box closed and turned on its side, place the seat upside down on top of the box. Align the back with the seat. In the absence of the shipping box, an elevated, flat surface may be suitable as well.

4 a)

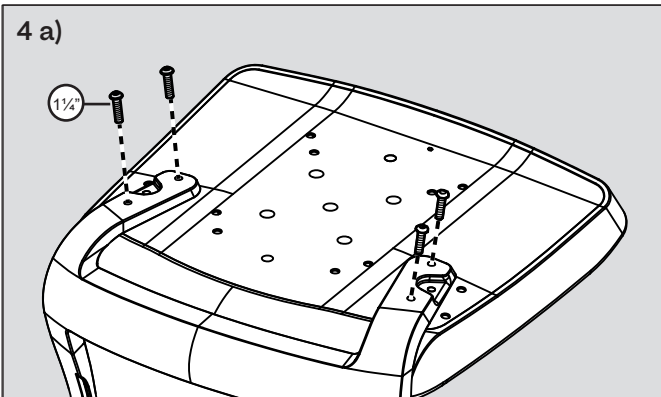

Align the 1 1/4" back + arm screws to threading located in the seat. Some pressure may be required to align the holes. Use the long end of the allen key to turn clockwise a few times to engage the screws, but do not fully tighten.

4 b)

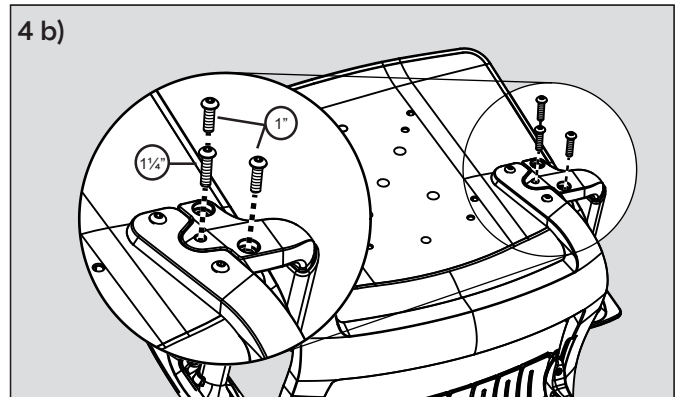

Place the adjustable arms into the tab as shown and fasten the remaining two 1 1/4" back + arm screws (one for each arm) into the tab without fully tightening, using the long end of the allen key. Then fasten outside the tab with the four 1" outer arm screws (two for each arm) without fully tightening, using the long end of the allen key.

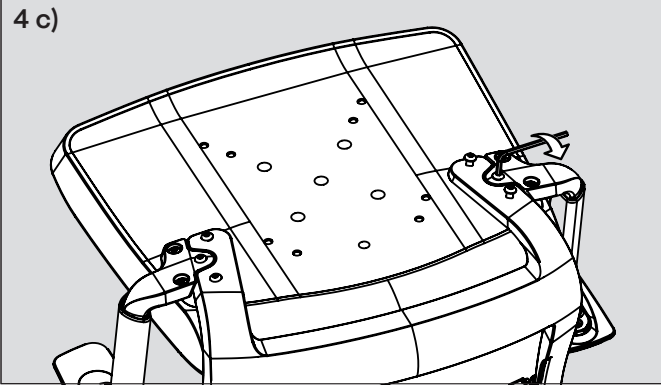

Once all ten screws (five per side) have been engaged, tighten all the screws using the short end of the allen key as shown.

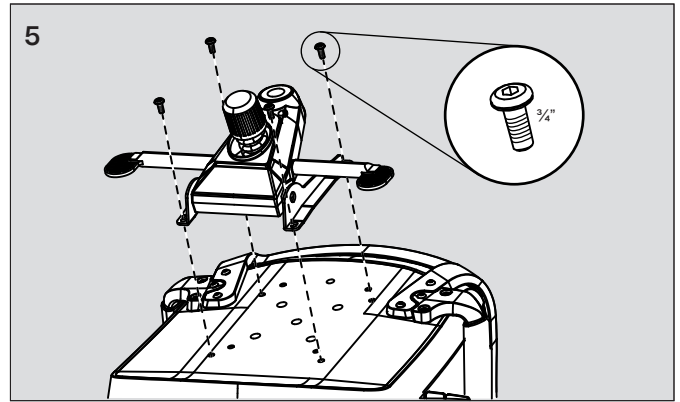

Align the mechanism to the four holes on the bottom of the seat as shown. Ensure the tilt tension knob is facing the front of the chair. Engage the four $\frac{3}{4}$ " mechanism screws, using the long end of the allen key, to secure the mechanism to the bottom of the seat, but do not fully tighten.

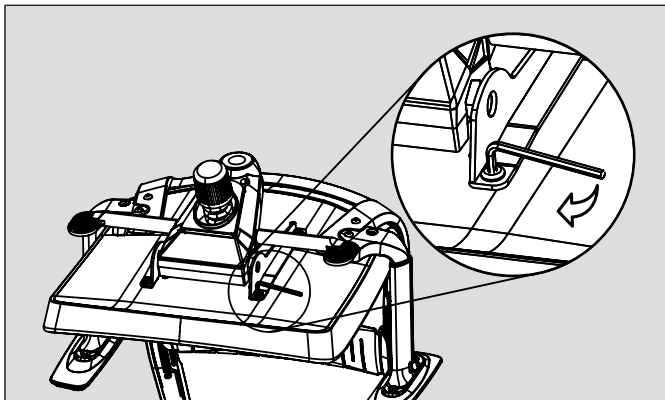

Once all four screws have been engaged, tighten all the screws using the short end of the allen key as shown.

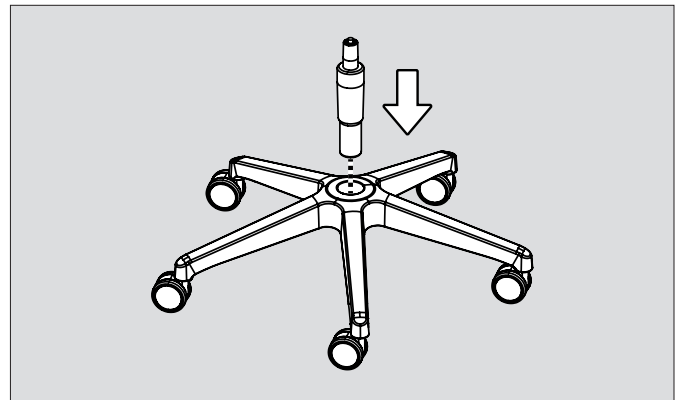

Put pneumatic height adjustment cylinder forcefully into the base. Some pressure may be required.

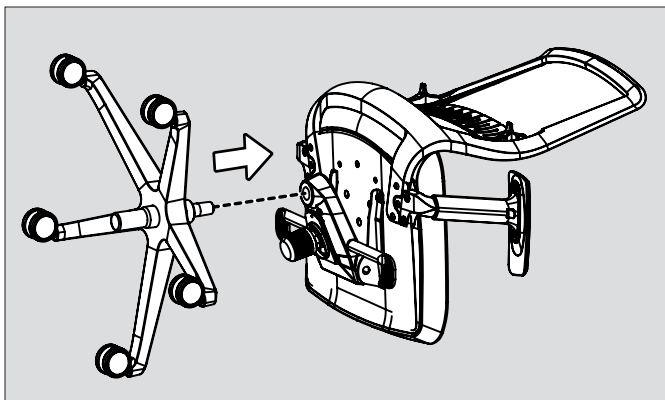

Take the chair off the box and place gently on the front edge of the seat. Push the cylinder/base assembly into the mechanism connection.

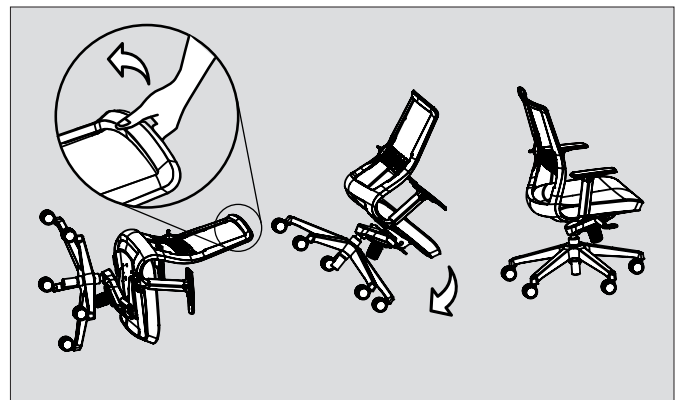

Once fully assembled, lift the chair from the top of the back as shown. Pull the chair upwards until fully upright. The chair will pivot onto casters. When fully upright, sit on the chair to fully set the cylinder in place.